

# PYC1690B

Prime Power:1200KW/1500KVA Standby Power: 1350KW/1688KVA Voltage: 400VAC

Powered by Yuchai YC12VC2070-D31 Engine

## Genset Performance

- 230/400VAC, 50Hz, 0.8PF, 3 Phases 4 wires
- Frequency drop  $\leq 3\%$
- Voltage regulation  $\leq 0.3\%$
- The steady state frequency  $\leq 0.5\%$
- The steady state voltage deviation  $\leq \pm 1\%$
- The transient frequency deviation  $\leq +10\% \leq -15\%$
- The transient voltage deviation  $\leq +20\% \leq -15\%$
- Frequency recovery time  $\leq 3S$
- Voltage recovery time  $\leq 1S(\text{Voltage} \pm 3\%)$
- THF (Telephone Harmonic Factor)  $< 3$
- TIF (Telephone Influence Factor)  $< 50$   
Comply to Standard NEMA MG1-22.43
- Standard equipped with ambient temperature 40°C  
Connecting radiator
- Built-in vibration isolator with high performance on shock absorption.

## Standard Configuration

- Guangxi Yuchai Engine
- Brushless synchronous alternator
- POWERTEC intelligent controller
- 40°C standard ambient temperature  
(50°C Optional)
- Molded case circuit breaker (3P)
- Float battery charger
- Battery connect wire
- Steel base frame
- Silencer, bellows, exhaust bend
- Manual book and files

## Optional Items

- Starting batteries
- Fuel tank
- Oil-water separator
- Sensor for low coolant level, low fuel/oil level
- Automatically monitoring & controlling system of city power
- Coolant heater
- Oil heater
- Heat exchanger--Water cooled tower system
- Silent type/Trailer
- Standardized container
- Design and construction of environmental protection; engineering for the Genset room.



## Diesel Engine

- Model: PYC1690B-YC12VC2070-D31
- Construction: High strength cylinder block, alloy forged steel crankshaft, alloy steel connecting rod and internal cooling oil pipe piston make the engine more durable.
- Intake: Charge inter-cooling
- Four valves + pressurized intercooling technology, sufficient air intake, full combustion and low fuel consumption.
- It adopts electric control unit pump technology, running smoothly; good transient speed regulation; strong loading capacity.
- The engine body is made of high-strength material, with cambered reinforcement mesh structure and 4-bolt main bearing structure. High stiffness, small vibration and low noise.
- The crankshaft is extruded with high quality alloy steel. Shaft diameter and fillet are hardened by heat treatment, making them anti-wear and long service life.
- World-class equipment and technology production; stable and reliable quality.
- Supporting dual-energy startup.
- One cylinder and one lid structure, with maintenance window on the side of the machine body for easy maintenance. Conform to non-road country T3 and European S3A standards.



### Engine Operating Environment Description:

1800r/min engine--altitude less than 1000 m, ambient temperature less than 40 °C

1500r/min engine--altitude less than 1000 m, ambient temperature less than 40 °C

## Alternator

- Optional brands: **Stamford / Marathon / Faraday / Engga / Mecc Alt**
- Brushless, 4 pole rotating magnetic field, single bearing with protective cover.
- Insulation: H Class.
- IP Class: IP23
- Cooling system
- AC exciter, rotate rectifying
- The stator winding is impregnated and the surface is covered with moisture-proof epoxy insulating paint.
- Rotor and exciter made with high temperature insulating resin, to satisfy tough environment.
- Rotor dynamic balancing complies with BS5625, class 2.5
- Sealed with advanced lubricating grease to prolong life of bearing.



**Notes: Above data of alternator comes from Stamford. Specification may alternated without advance notice.**

## Standard

- 3 phases voltage:  $U_a, U_b, U_c$
- Frequency F1
- Apparent power PR
- Power factor PF
- Coolant temperature WT
- Temperature °C display
- Oil pressure OP
- Engine speed
- 3 phases current:  $I_a, I_b, I_c$
- Active power PA
- Power factor PF
- Temperature °C display
- KPa/Psi/Bar display
- Battery voltage V
- Running Hour
- Starting timer:(999999)



## Standard Protection

### Genset Protection

- Programmable I/O signal
- Emergency stop

### Engine Protection

- Stop for over speed
- Low oil pressure
- High Coolant temperature
- Sensor fail
- Alarm for low/high battery voltage
- Low battery voltage
- Fail to start/Cranking fail

### Alternator Protection

- Over Voltage
- Over current
- Voltage signal lost
- Over Voltage
- Over frequency
- Under frequency

### Control System Components

- Manual/auto/stop/start
- Setting button
- Fault status indicators
- Screen menu selection button
- Emergency stop button
- Digital displayer



## Communication Interface (Option)

- International standard MODBUS communication protocol RS232/ RS485 is suitable for remote control and monitor; It is easy integrated with SCADA;.

**Notes: Above data of controller comes from POWERTEC GC6110. Customized solutions is available as required**

## Genset

Model	PYC1690B
Prime Rating (kw)	1200
Standby Rating (kw)	1350
Rate voltage(V)	400
Rate current(A)	2165
Power factor	0.8
Frequency(Hz)	50

## Engine

Engine Model	YC12VC2070-D31
Gross Engine output-Prime (kw)	1380
Gross Engine output-Standby (kw)	1520
Bore * stroke (mm)	200*210
Cylinders and structure	12 V-Type
Displacement(Liter)	79.17
Compression Ratio	13.5: 1
Intake way	Supercharge/Water-Air intercooler
Max intake resistance (KPa)	5
Air intake (m3/h)	9250
Max exhaust back pressure (KPa)	10
Exhaust gas flow (m3/h)	19820
Exhaust temp (°C)	550
Cooling way	Water Radiator & Fan
Fan exhaust flow (m3/min)	2520
Coolant capacity (L)	608
Highest water temperature(°C)	95
Minimum air opening to room (m2)	9.0/8.1
Thermostat range (°C)	75-85
Max oil temperature (°C)	110
Lubrication system oil capacity (L)	310
Rate load fuel consumption(L/H)	339.2
Standard Governor/Class	EUP

## Alternator

Rated Voltage(V)	400/230
Output Way	3 Phases, 4 wires
Rated power factor	0.8
Exciter	Brushless, Self-exciter
Max voltage regulation	±1%
Phase	3
Protection class	IP21-23
Insulation class	H

## Controller

Brand	POWERTEC GC7110.2
-------	-------------------

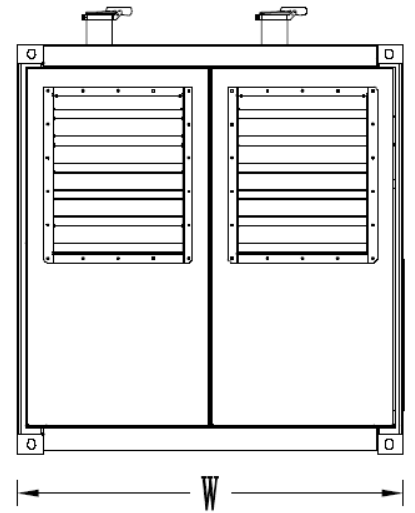
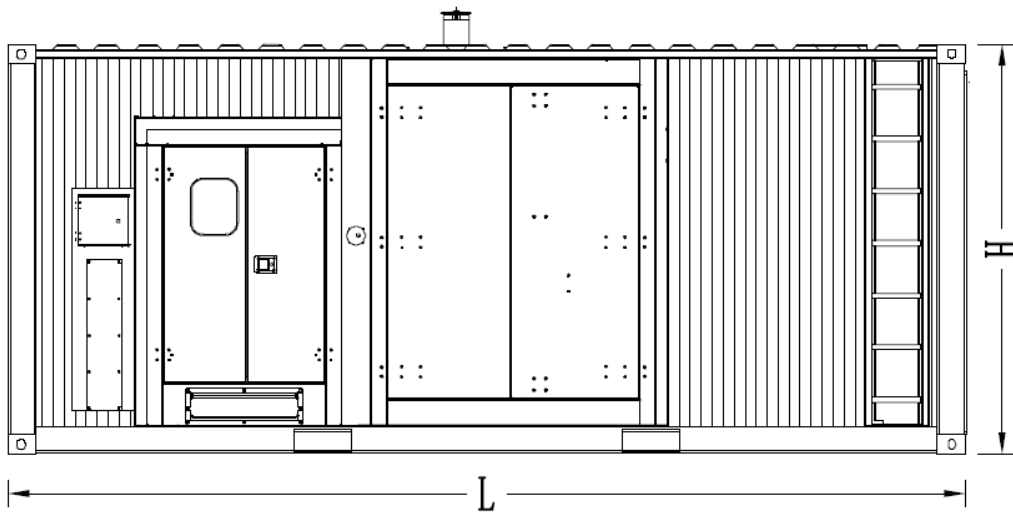
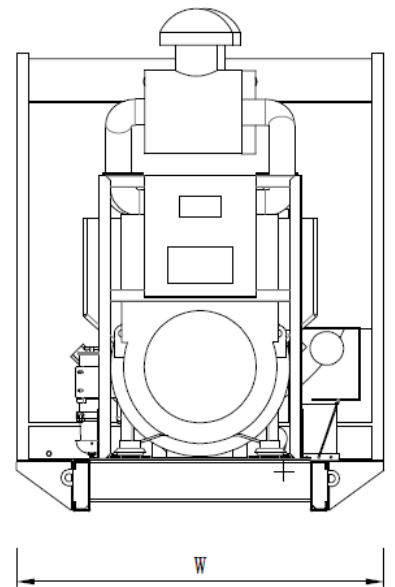
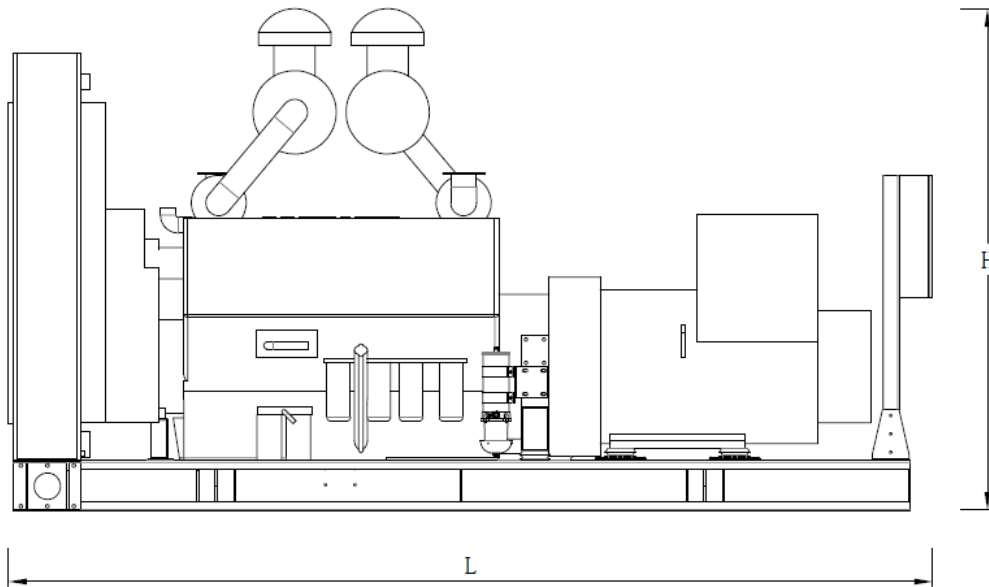

Type	Dimension (mm) (L*W*H)	Weight (kg)	Fuel Tank Capacity (L)
Open Type	5846*2320*2714	12800	-
Silent Type	-	-	-

**Contact Us**

## Powertec Generator System Inc.

**Add:** Danshui Yanna Industry Zone, Huiyang, Huizhou, Guangdong, China  
**Tel:** +86 752-3911119 / 3911118  
**Fax:** +86 752-3911110  
**Web:** [www.powertec.com.cn](http://www.powertec.com.cn)  
**Email:** [powertec@powertec.com.cn](mailto:powertec@powertec.com.cn)